

Accessories for XLPE-insulated
high and extra-high voltage cables
72.5 – 550 kV

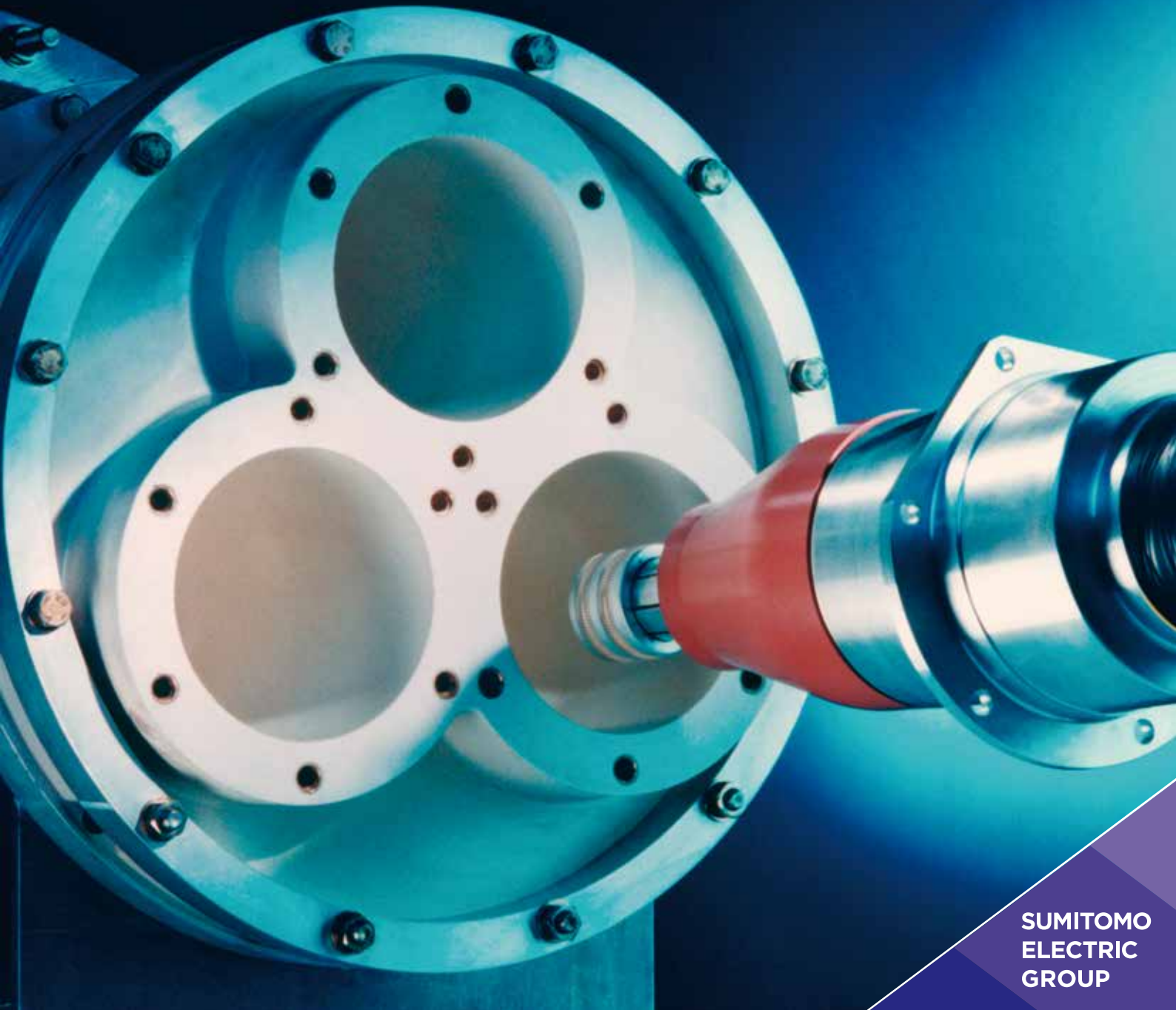

Content

Welcome to Südkabel	3
Cable accessories	4
Built-in terminations	4
EHSVS and EHTVS compact terminations	6
Plug-in product range 72.5 kV	8
Outdoor terminations	10
Outdoor terminations filled with liquid insulation	10
Gas-insulated outdoor terminations	12
Dry outdoor terminations	14
Cable joints	16
SEHDV(CB) cable joints 72.5 kV – 550 kV	16
Fitting material for cable accessories	18
Our product and service range	20



The power of innovation:

A tradition of thinking outside the box

The Achievement Principle

A pioneering spirit and the will to achieve – these are qualities that drive a history of success stretching back more than 100 years. Superior products, comprehensive service, and careful project management are what define us – and what underlies our long-standing partnerships with energy providers and the electrical engineering industry.

Our primary focus – then, as now – is on the individual requirements of every one of our customers. Whether as a pioneer in XLPE technology or as developer of cutting-edge manufacturing techniques – it is only through close dialog with you the customer that we can succeed in bringing to market the innovations that have impacted energy transmission and distribution so decisively. And we will continue to focus on developing even better solutions, more advanced manufacturing techniques, and more comprehensive services, without ever sacrificing quality. To achieve this, we use the very latest technologies: our entire portfolio is being developed, manufactured and tested in our headquarters in Mannheim with modern techniques like computerised systems.

Inquiring Minds

and the Power of Innovation

Maintaining and improving our knowledge and know-how are important parts of the entrepreneurial culture at Südkabel. The drive to innovate is one of our traditions. Our company is known worldwide as a pioneering specialist for cutting-edge products and technology. Our teams are always on the lookout for new materials, manufacturing or assembly processes that promise better utility and safety. We work hard toward further improving our user-friendly solutions – solutions that meet all our customers' requirements.

Pioneers in XLPE Cable Technology

Ever since the company was founded, our goal has been to provide new solutions that guarantee our customers greater safety and improved procedures. Südkabel established its reputation as a pioneer in XLPE technology when Germany's polymeric-insulated medium-voltage cables were laid in the 1960s. And many more trailblazing innovations followed: The planning and construction of the first 110 kV XLPE cable system in Germany, the first 400 kV XLPE cable system in the European transmission network, and last but not least, the manufacture and installation of many 500 kV XLPE cable systems in Russia, Asia, Africa, and South America with conductor cross-sections of up to 2500 mm².

High-performance technology: Accessories for complex projects

Südkabel accessories are important components for XLPE-insulated high and extra-high voltage cables. Here, too, the development of new products were path-breaking, such as joints for 400 kV XLPE-insulated cables, which in 1995 succeeded in the first world-wide prequalification according to CIGRE (International Council on Large Electric Systems). Our compact terminations are based on this advanced technology. They are excellent examples of how we enhance safe and easy to-install accessories for XLPE-insulated high and extra-high voltage cables. They can be used for almost all types of XLPE-insulated cables with vastly different conductors, screens, sheaths, and armouring. Südkabel accessories can also be installed on EPR insulation up to 170 kV. The optical fibres in screens can be decoupled in all accessories. Accessories for extra-high voltage applications can be supplied with integrated sensors for partial discharge detection. All cable accessories are designed for a long life, the same as expected for energy cables themselves.

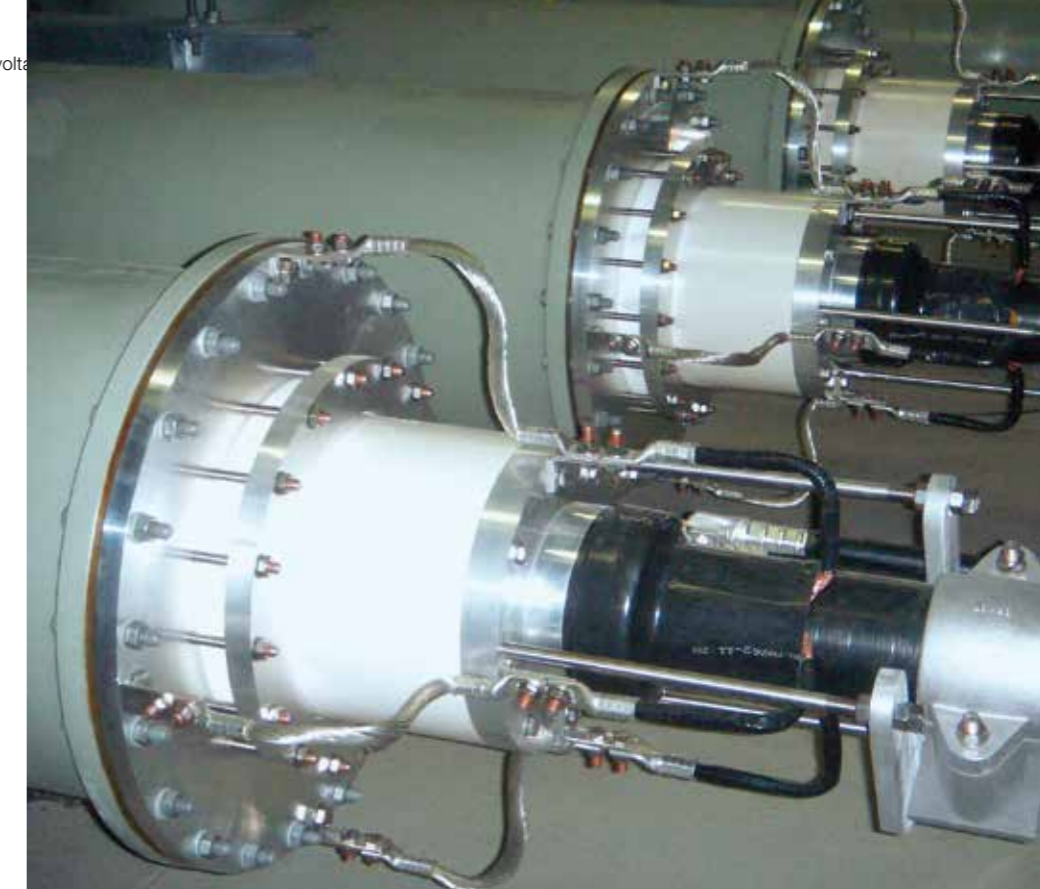

A wide range of high performers

Accessories for XLPE-insulated high- and extra-high voltage cables

Performance at a glance

The **plug-in compact terminations** of type EHSVS for gas-insulated switching systems and type EHTVS for oil-filled transformers are completely maintenance-free and can be installed quickly and safely. They are also very environmentally friendly, since the solid insulation contains no gaseous or liquid components. The short installation length of the epoxy resin insulator enables a compact design of the cable enclosure. The installation position of the compact termination can be chosen freely, as no expansion volume for liquids has to be taken into account.

Assembly is quick and easy: Since the insulator can be pre-installed as a socket, the cable can be installed separately from switchgear or transformers. The compact termination is then simply plugged into the pressure-tight insulator socket.

Cables can be tested on-site for voltages up to 170 kV at the switchgear without the need for any additional equipment because for the compact termination a corresponding test adapter is available.

Relevant dimensions for compact terminations can be found in the following publications: IEC 62271-209 (for gas-insulated metal-enclosed switchgear) and EN 50299 (for oil-immersed cable termination for transformers and reactors).

For **outdoor terminations**, Südkabel distinguishes between terminations filled with liquid insulation type EHFVC, the dry, gas-filled type EHFVCS and the dry, solid-insulated type EHFST. All these types are self-supporting due to integrated elements made of reinforced plastic. A dry, flexible outdoor termination type EHFS for special applications is also available. The types EHFVC and EHFST are characterized by their slim design and low weight. On request, we can also produce a variant with a porcelain insulator for all voltage levels, designated type EHFV. In all variants, the electric field is controlled by means of prefabricated stress cones made of silicone rubber.

A balancing volume in the top part of the insulator compensates for temperature-related volume changes in the insulating compound, resulting in a pressure- and maintenance-free system.

In addition to the composite insulator, the most important component of the dry, gas-filled type EHFVCS is a complete compact termination for controlling the electrical field. The on-site assembly time can thus be reduced mainly to its assembly, since the composite insulator can be delivered pre-assembled.

The dry, solid-insulated type EHFST contains no liquid or gaseous insulating media and therefore has a further reduced assembly time.

The Südkabel accessories portfolio also includes **joints** for voltage levels from 72.5 kV to 550 kV. In 1993, Südkabel was the first manufacturer to provide prefabricated and pre-tested joints for extra-high voltage levels from 245 kV to 550 kV.

All joint types are basically maintenance-free as they contain no gaseous or liquid components. The SEHDV type slip-on joint is used for through-connection of the screens, while the SEHDVCB type allows for the potential separation of the screens on both sides. This sectionalising joint is used for cross-bonding of cable screens, or for single-point screen bonding in subsections.

Information on tests and testing requirements

The test requirements for accessories of XLPE-insulated high and extra-high voltage cables are given in IEC 60840 for operating voltages up to max. 170 kV and in IEC 62067 for operating voltages above 170kV.

All accessories from SÜDKABEL (plug-in terminations, outdoor terminations, joints) meet the requirements of the relevant test specifications.

EHSVS 72.5/123/145 Type D

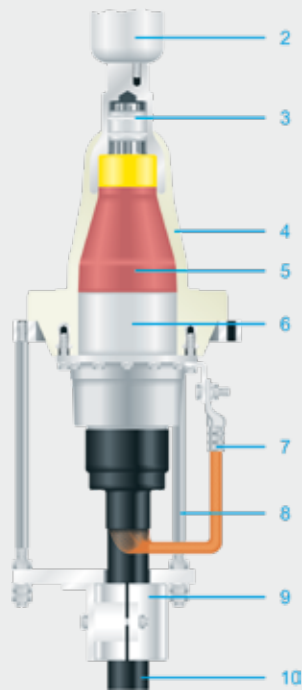

EHSVS 123/145/170 Types A/B

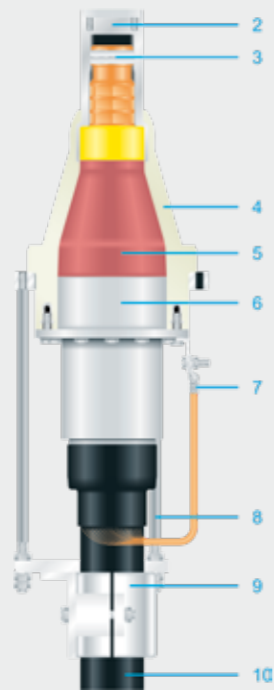

EHSVS 245/300/362/420/550 kV Types E/F/H

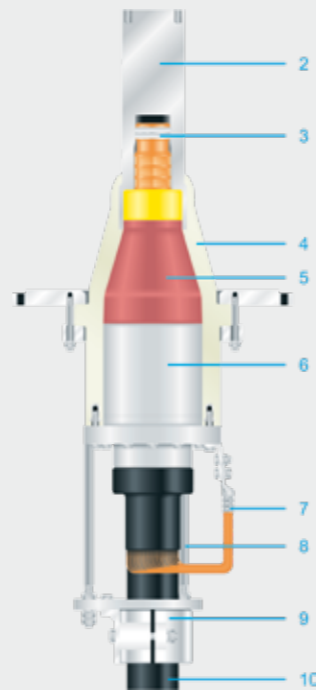

EHTVS 72.5/123/145 Type D

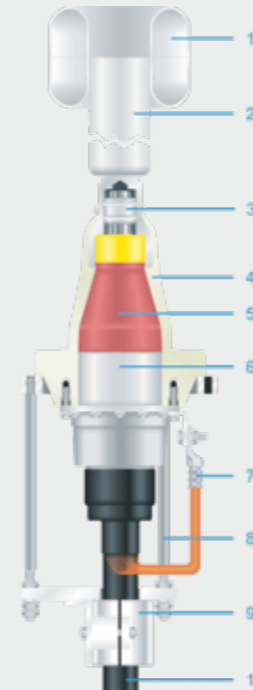

EHTVS 245/300 Type E

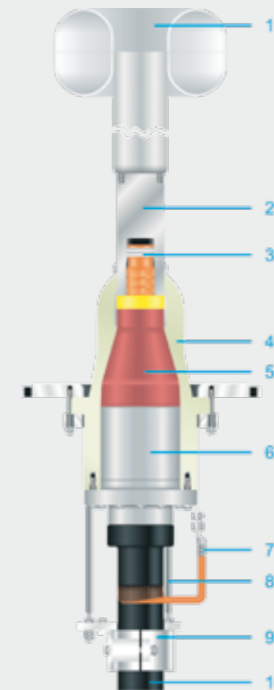

EHTVS 362/420/550 Type F

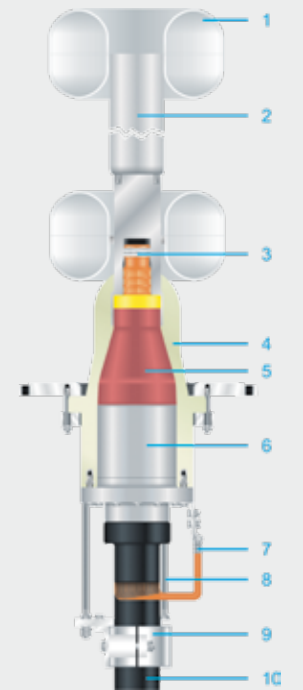

1. Corona shield 2. Connector 3. Pluggable current contact 4. Epoxy resin insulator 5. Silicone rubber stress cone 6. Inlet with inner spring assembly 7. Screen connection 8. Clamp support 9. Cable clamp 10. XLPE-insulated cable

1. Corona shield 2. Connector 3. Pluggable current contact 4. Epoxy resin insulator 5. Silicone rubber stress cone 6. Inlet with inner spring assembly 7. Screen connection 8. Clamp support 9. Cable clamp 10. XLPE-insulated cable

Compact terminations

EHSVS (in SF₆-enclosure) and EHTVS (for oil-filled transformers)

Type G

- For voltages up to 72.5 kV
- In accordance with IEC 62271-209, for use in cable enclosures at voltage level 72.5 kV

Types A/B

- For voltages from 123 kV to 170 kV
- Single-phase insulator design in accordance with the interface dimensions of IEC 62271-209
- Outer geometry and dimensions for Types A/B are identical, but are different at the plug end
- Consists of a pre-assembled stress cone made of silicone rubber for permanent elastic connection to the insulator via spring assemblies
- Current contact via custom contact springs
- Type B, which has a larger inner diameter, can generally be used for conductor cross-sections of 630 mm² up to max. 2500 mm²

Type C

- For voltages from 72.5 kV to 145 kV
- Special compact cable entry uses a common three-phase epoxy resin insulator
- Stress cone made of silicone rubber, with inner spring assembly and pluggable current contact
- For use in SF₆-enclosure only

Type D

- For voltages from 72.5 kV to 145 kV
- Interface dimensions comply with IEC 62271-209 for voltages from 123 kV to 145 kV
- Like Types A/B, uses a single-phase epoxy resin insulator
- Stress cone made of silicone rubber, with inner spring assembly and pluggable current contact

Types E/F/H

- For voltages from 245 to 300 kV (Type E) and from 362 to 550 kV (Type F)
- Type H for conductor cross-sections up to 3200 mm²
- All variants consist of a pre-assembled stress cone made of silicone rubber for permanent elastic connection with the insulator via spring assemblies
- Design essentially the same as Types A/B
- Single-phase insulator in accordance with the interface dimensions of IEC 62271-209

All insulators for the above-mentioned compact terminations – with the exception of Type C – can be used for the cable enclosures in both SF₆ enclosures as well as in oil-filled transformer enclosures in compliance with EN 50299-1/-2 (or similar) using the same pluggable parts. The compact terminations for transformers are labelled EHTVS, the only technical difference being one or two additional corona shield(s).

Over the years, experience with built-in terminations for gas-insulated switchgears and transformers has proved just how valuable they are. The dry, compact terminations EHSVS or EHTVS have been established in the market since 1995. Additionally, they are suitable for use in climate-friendly substitute gases.

Highest voltage U _m	kV	72.5	123	123	145	145	170	245	300	362	420	550
Insulator type	–	G	D/C	A/B	D/C	A/B	A/B	E	E	F/H	F/H	F/H
In SF ₆ -enclosure	–	EHSVS	EHSVS	EHSVS	EHSVS	EHSVS	EHSVS	EHSVS	EHSVS	EHSVS	EHSVS	EHSVS
In oil-transformer enclosure	–	EHTVS	EHTVS	EHTVS	EHTVS	EHTVS	EHTVS	EHTVS	EHTVS	EHTVS	EHTVS	EHTVS
Impulse lightning voltage	kV	350	550	550	650	650	750	1050	1050	1175	1425	1675
Switching impulse voltage	kV	-	-	-	-	-	-	-	850	950	1050	1240
Normative document	IEC	60840	60840	60840	60840	60840	60840	62067	62067	62067	62067	62067
Cu/Al conductor (min.)	mm ²	95	150	150	240	240	240	400	400	500	630	800
Cu/Al conductor (max.)	mm ²	800	800	2500	800	2500	2500	2500	2500	3200	3200	3200
Rated current (max.) *	A	3150	3150	3150	3150	3150	3150	3150	3150	3150	3150	3150
Rated peak current *	kA	100	100	170	100	170	170	170	170	170	170	170
Rated short-time withstand current *	kA/s	40/3	40/3	50/3 63/1	40/3	50/3 63/1	50/3 63/1	63/3	63/3	63/3	63/3	63/3
Max. radial force effect	kN	5	5	5	5	5	5	5	5	5	5	5
Max. longitudinal force effect	kN	10	10	10	10	10	10	10	10	10	10	10

Table 1 Data sheet for compact terminations

* Subject to cable conductor cross section

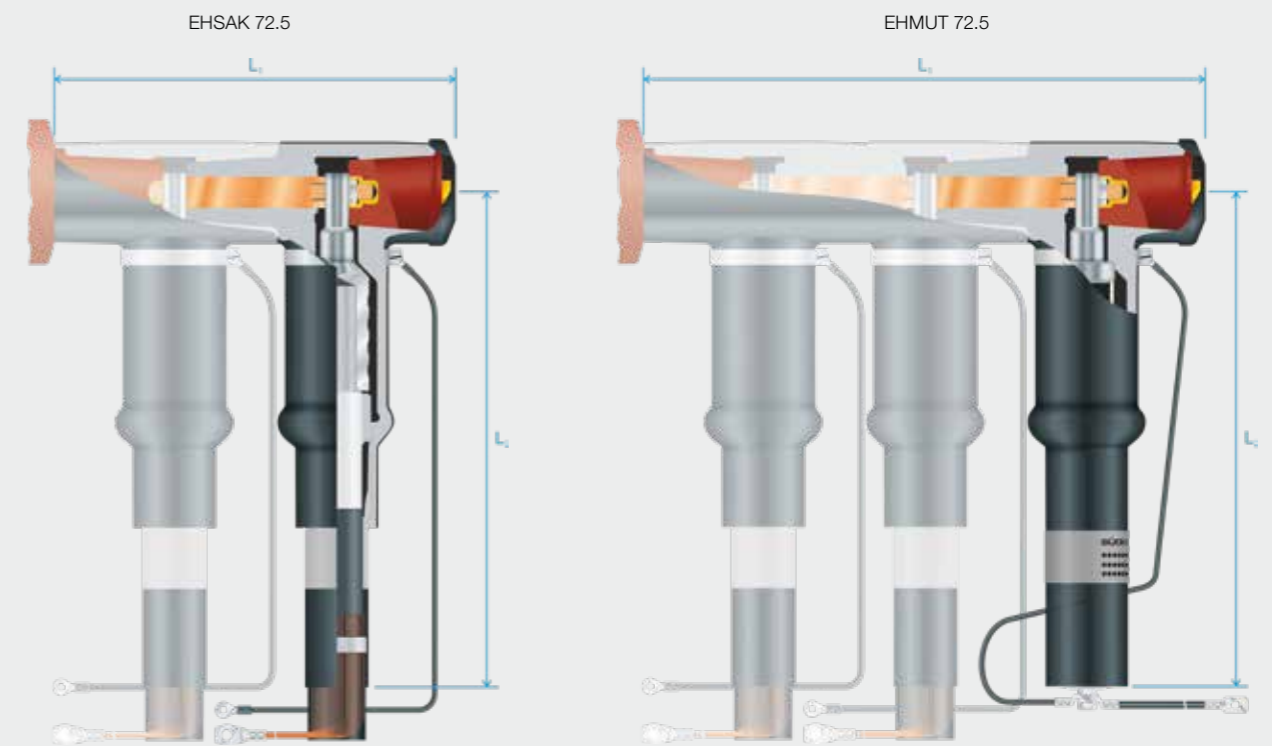
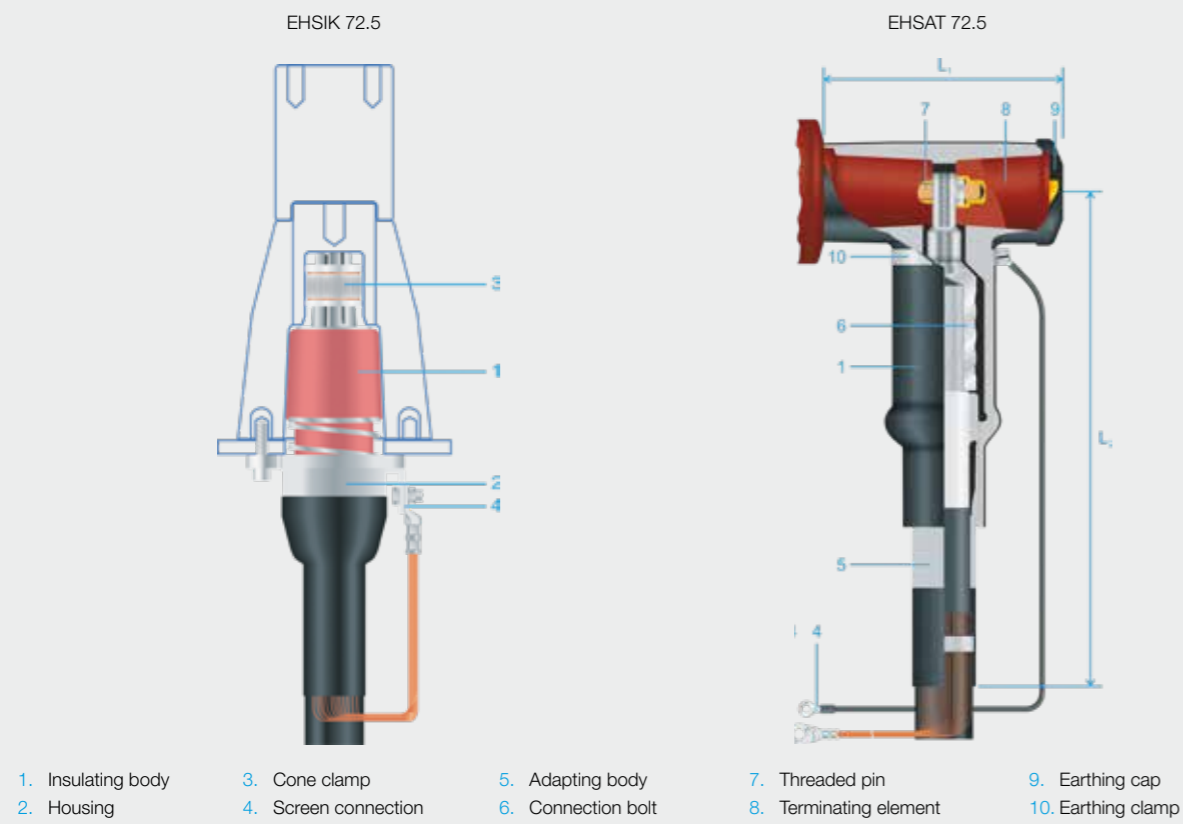

- 1. Insulating body
- 2. Housing
- 3. Cone clamp
- 4. Screen connection
- 5. Adapting body
- 6. Connection bolt
- 7. Threaded pin
- 8. Terminating element
- 9. Earthing cap
- 10. Earthing clamp

Plug-in terminations

Product range 72.5 kV

EHSIK 72.5

- GIS inner cones termination for connection to metal enclosed switchgear and transformers
- Suitable for inner cone bushings interface type 3 according to EN 50180, EN 50181 and draft EN 50673
- Adaptable to interface according to IEC 62271-209
- For voltages up to 72.5 kV
- Conductor cross-section from 95 to 800 mm²
- Cone clamp conductor connection
- Rated current up to 1250 A
- Qualified and type tested according to IEC 60840

EHSAT 72.5

- Space saving direct parallel connection to EHSAT 72.5 without coupling device
- Conductor cross-section from 95 to 1000 mm²
- Cone clamp conductor connection
- Rated current up to 1250 A

EHSAT 72.5

- T-shaped plug-in termination for connection to metal enclosed switchgear and transformers
- Suitable for outer cone bushings according to EN 50180, EN 50181 interface type F
- For voltages up to 72.5 kV
- Conductor cross-section from 95 to 1000 mm²
- Screw type conductor connection
- Rated current up to 630 / 1250 / 2500 A
- Qualified and type tested according to IEC 60840

EHMUT 72.5

- T-shaped surge voltage limiter
- Use in conjunction with EHSAT 72.5 or EHSAT 72.5
- Space saving solution directly connected at the switchgear
- Metal-oxide surge arrester conforms to requirements of IEC 60099-4

For the 72.5 kV voltage level, SÜDKABEL offers a complete portfolio of compact terminations for inner cone and outer cone connections. For outer cone applications, the combination with a coupling plug or with a surge arrester is also available.

Highest voltage U _m	kV	72.5	72.5	72.5	72.5
Type	–	EHSIK	EHSAT	EHSAT	EHMUT
Impulse lightning voltage	kV	350	350	350	350
Switching impulse voltage	kV	–	–	–	–
Normative document	IEC	60840	60840	60840	60099-4
Cu/Al conductor (min.)	mm ²	95	95	95	–
Cu/Al conductor (max.)	mm ²	800	1000	1000	–
Rated current (max.) *	A	1250	2500	1250	–
Rated peak current *	kA	100	100	100	–
Rated short-time withstand current *	kA/s	40/3	40/3	40/3	–
Length L ₁	mm	–	253	450	625
Length L ₂	mm	–	550	550	550

Table 2 Data sheet for plug-in terminations 72.5 kV
* Depending on cable conductor cross-section

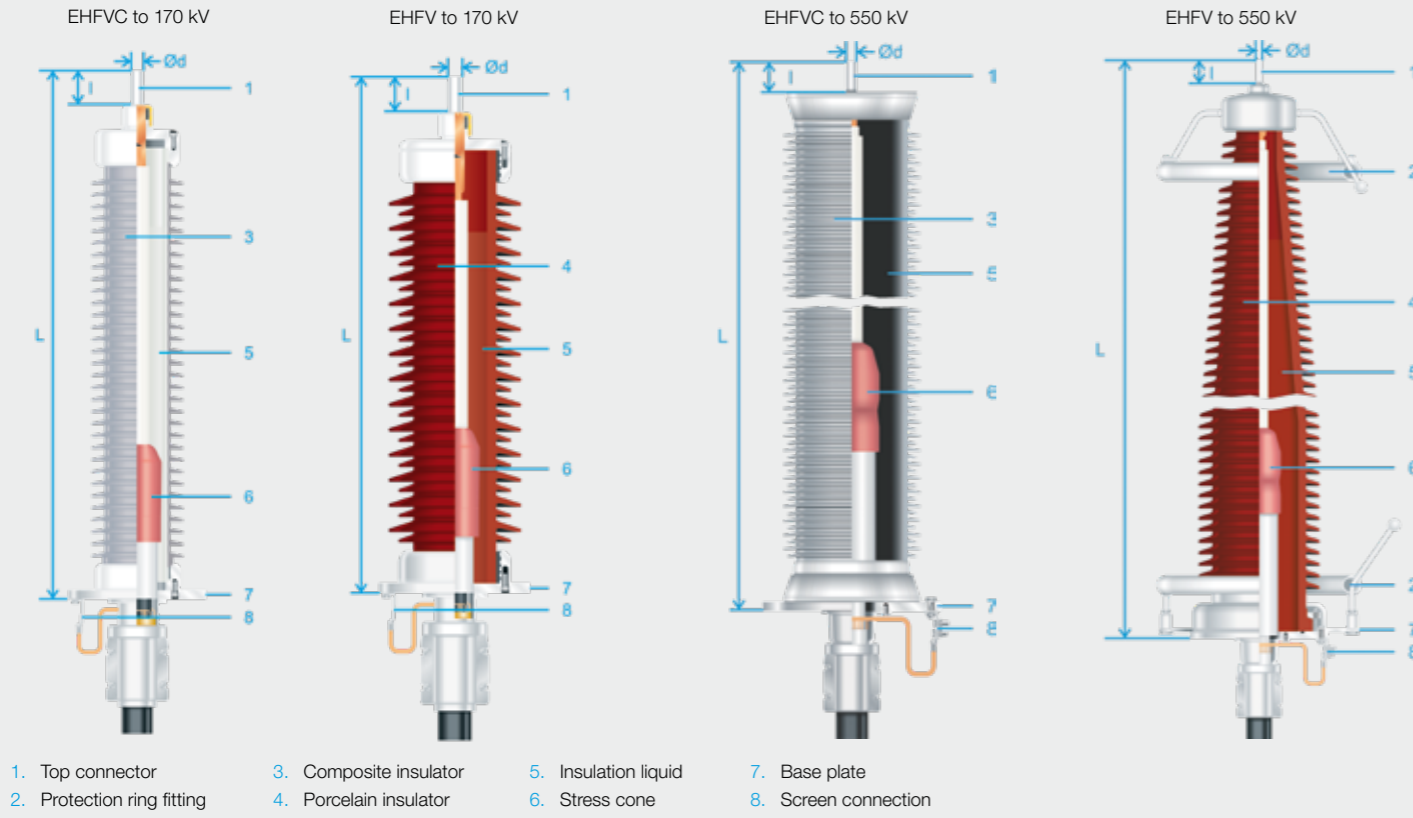

Outdoor terminations

Liquid insulation

Variants EHFVC (with composite insulator) and EHFV (with porcelain insulator)

- Primary component: composite insulator made of fibreglass-reinforced
- plastic support tubing with integrally cast sheds of high-grade silicone rubber, or with porcelain insulator
- Field control by means of a push-on stress cone made of silicone rubber that also seals the base of the termination
- Filled with a synthetic insulating liquid (polyisobutylene)
- Optional equipment: flashover protective fittings (arcing horns)
- Also available: insulated installation with special cast-resin post insulators

- Meets the requirements of relevant test specifications (e.g. IEC 60840, IEC 62067, IEC 60815)
- Insulators with extended creepage paths for use in highly polluted areas are available
- Cantilever load at conductor bolt dependent on type and length of insulator
- Possible modification of external insulation to correct for atmospheric conditions (for installations at altitudes > 1000 m) by increasing the arcing distance with longer insulators or by using accessories with a higher voltage level
- Short overall height insulator up to a maximum of 30° inclination

Highest voltage U_m	kV	72.5	123	145	170	245	300	362	420	550
Variant with composite insulator	–	EHFVC	EHFVC	EHFVC	EHFVC	EHFVC	EHFVC	EHFVC	EHFVC	EHFVC
Variant with porcelain insulator	–	EHFV	EHFV	EHFV	EHFV	EHFV	EHFV	EHFV	EHFV	EHFV
Impulse lightning voltage	kV	350	550	650	750	1050	1050	1175	1425	1550
Switching impulse voltage	kV	–	–	–	–	–	850	950	1050	1175
Normative document	IEC	60840 60815	60840 60815	60840 60815	60840 60815	62067 60815	62067 60815	62067 60815	62067 60815	62067 60815
Cu/Al conductor (min.)	mm ²	95	150	240	240	400	400	500	630	800
Cu/Al conductor (max.)	mm ²	3200	3200	3200	3200	3200	3200	3200	3200	3200
Rated current (max.) *	A	3150	3150	3150	3150	3150	3150	3150	3150	3150
Rated peak current *	kA	170	170	170	170	170	170	170	170	170
Rated short-time withstand current *	kA/s	63/3	63/3	63/3	63/3	63/3	63/3	63/3	63/3	63/3
Standard pollution class	–	≥ d/III heavy	≥ d/III heavy	≥ d/III heavy	≥ d/III heavy	≥ d/III heavy	≥ d/III heavy	≥ d/III heavy	≥ d/III heavy	≥ d/III heavy
Length with class d/III (approx.) EHFVC/EHFV [L]	mm	1350/ 1020	1710/ 1490	1980/ 1700	2290/ 1950	2590/ 2540	3070/ 3040	3580/ –	4100/ –	5020/ 5130
Weight with class d/III (approx.) EHFVC/EHFV **	kg	80/ –	90/ 175	95/ 195	105/ 235	370/ 470	390/ 570	780/ –	960/ –	1100/ 1400
Base plate dimensions [a]	mm	420	420	420	420	600	600	700	700	700
Hole distance [b]	mm	345	345	345	345	500	500	600	600	600
Hole diameter [Ø c]	mm	18	18	18	18	23	23	23	23	23
Bolt diameter [Ø d] (≤1000 mm ² />1000 mm ²)	mm	30/50	30/50	30/50	30/50	30/50	30/50	30/50	30/50	30/50
Bolt length [l]	mm	100	100	100	100	100	100	100	100	100

Table 3 Data sheet for outdoor terminations filled with insulating liquid

* Depending on cable conductor cross-section;
** Without cable

Base plate dimensions

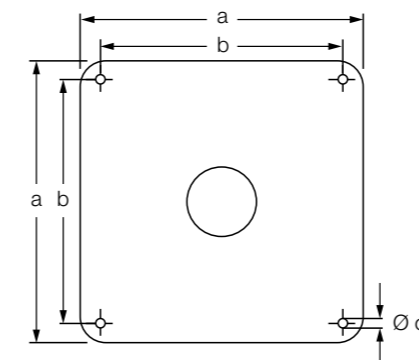

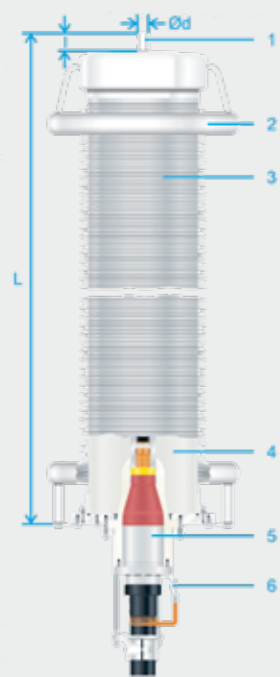

1. Top connector
2. Protection ring fitting
3. Composite insulator
4. Insulating gas
5. Compact termination
6. Screen connection



Highest voltage U_m	kV	123	145	170	245	300	362	420	550
Variant with composite insulator	–	EHFVCS	EHFVCS	EHFVCS	EHFVCS	EHFVCS	EHFVCS	EHFVCS	EHFVCS
Impulse lightning voltage	kV	550	650	750	1050	1050	1175	1425	1675
Switching impulse voltage	kV	-	-	-	-	850	950	1050	1240
Normative document	IEC	60840 60815	60840 60815	60840 60815	62067 60815	62067 60815	62067 60815	62067 60815	62067 60815
Cu/Al conductor (min.)	mm ²	150	240	240	400	400	500	630	800
Cu/Al conductor (max.)	mm ²	2500	2500	2500	2500	2500	3200	3200	3200
Rated current (max.) *	A	3150	3150	3150	3150	3150	3150	3150	3150
Rated peak current *	kA	170	170	170	170	170	170	170	170
Rated short-time withstand current *	kA/s	50/3 63/1	50/3 63/1	50/3 63/1	50/3 63/1	50/3 63/1	50/3 63/1	50/3 63/1	50/3 63/1
Standard pollution class	–	≥ d/III heavy	≥ d/III heavy	≥ d/III heavy	≥ d/III heavy	≥ d/III heavy	≥ d/III heavy	≥ d/III heavy	≥ d/III heavy
Length with class d/III (approx.) [L]	mm	1925	2192	2192	3120	3120	3650	5240	5240
Weight with class d/III (approx.) **	kg	180	200	200	350	350	650	800	800
Max. longitudinal force effect	kN	2	2	2	2	2	2	2	2
Base plate dimensions [a]	mm	420	420	420	600	600	800	800	800
Hole distance [b]	mm	345	345	345	500	500	700	700	700
Hole diameter [Ø c]	mm	18	18	18	23	23	23	23	23
Bolt diameter [Ø d]	mm	50/60***	50/60***	50/60***	60	60	60	60	60
Bolt length [l]	mm	100	100	100	100	100	100	100	100

Table 4 Data sheet for gas-filled outdoor terminations

* Depending on cable conductor cross-section;

** Without cable

*** ≤1600 mm²/ $>$ 1600 mm²

Outdoor terminations

Gas insulation

Advantages

- Considerably shorter on-site assembly time compared with terminations filled with liquid insulation
- Very short cable length to work with
- Can be installed at any position depending on shed alignment
- Plug-in system allows for insulated assembly

Properties

- Composite insulation of fibreglass-reinforced plastic support tubing with integrally cast sheds of high-grade silicone rubber
- Integrated compact termination as a component of the electric field control
- The socket-type epoxy-resin insulator is fastened to the base plate of the termination

- Permanent elastic field control made of silicone rubber connected to the insulator via spring assemblies
- Filled with high-grade insulating gas
- Optional equipment: flashover protective fittings (arcing horns)
- Meets the requirements of relevant test specifications (e.g. IEC 60840, IEC 62067, IEC 60815)
- Insulators with extended creepage paths for use in highly polluted areas
- Cantilever load at conductor bolt dependent on type and length of insulator being used
- Possible modification of external insulation to correct for atmospheric conditions (for installations at altitudes $>$ 1000 m) by increasing the arcing distance with longer insulators or by using higher-voltage accessories
- Also available with optional heating system for use in very low temperature environments

Base plate dimensions

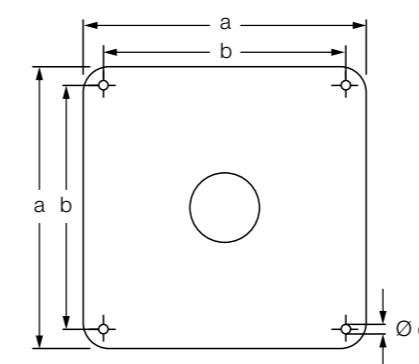

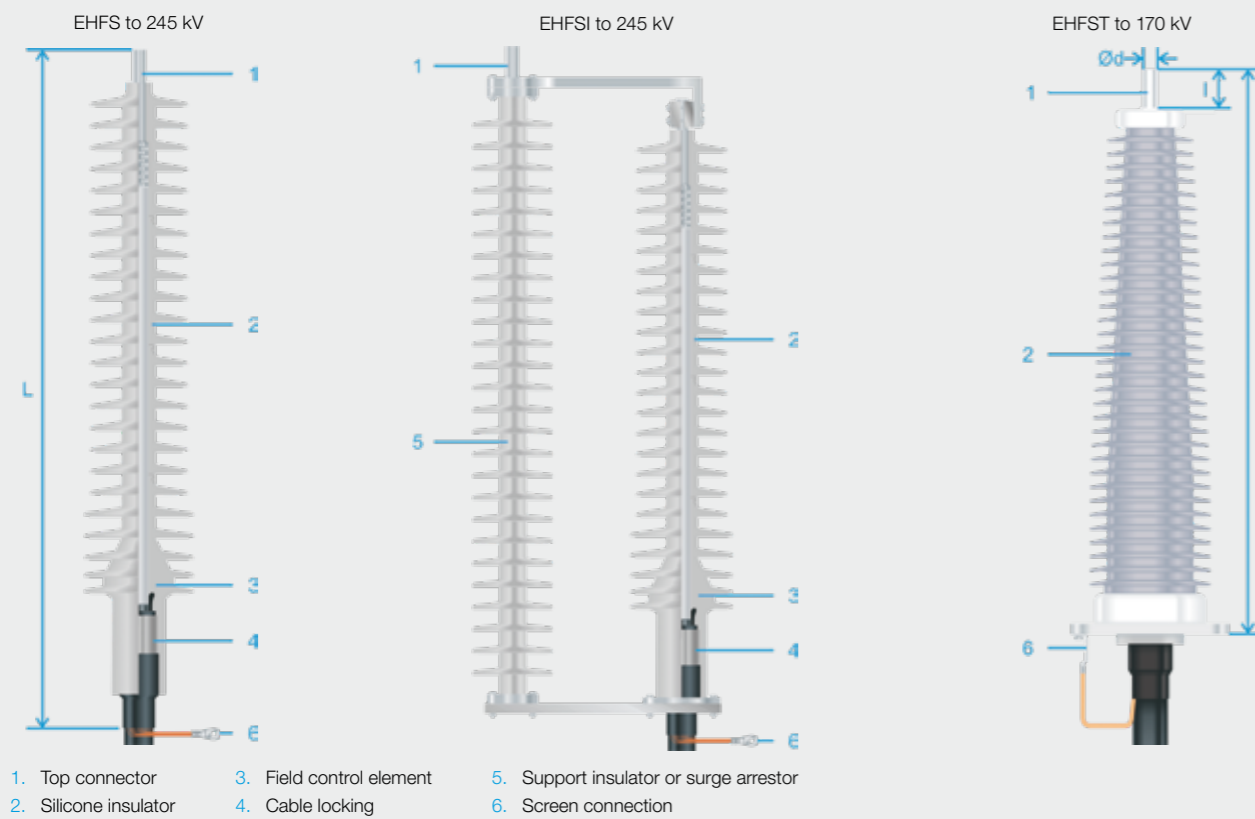

1. Top connector 3. Field control element 5. Support insulator or surge arrester
 2. Silicone insulator 4. Cable locking 6. Screen connection

Outdoor terminations

Dry and solid insulation

Advantages

- Insulator of high grade silicone rubber
- Field control of silicone rubber already integrated
- Significant shorter installation times on site compared to outdoor terminations filled with compound
- Horizontal assembly possible; lifting tools for integration of termination into console available
- Arbitrary installation position depending on shed alignment
- Free of any insulating fluids or gases
- Non-flammable

EHFS (option flexible) and

EHFSI (option flexible/supported)

- Suitable for pre-assembled deployment, e.g. in temporary site cables
- Support insulator or surge arrester as supporting element
- Parallel support can be installed independently from cable termination

EHFST (option self-supporting)

- Integrated supporting elements of reinforced plastic
- No additional filling of insulating medium required
- Insulated installation with special cast-resin post insulators if required
- Baseplate rotatable

Properties

- Insulator and field control element pre-tested before shipment
- Meets requirements of relevant test specifications like IEC 60840, IEC 62067, IEC 60815
- Insulating body with extended creepage path for use in highly polluted areas is available
- Cantilever load at conductor bolt dependent on type and length of insulator
- Possible modification of external insulation to correct for atmospheric conditions (for installations at altitudes > 1000 m) by increasing the arcing distance with longer insulator or using accessory with a higher voltage level

Base plate dimensions EHFST

Highest voltage U_m	kV	72.5	123	145	170	245
Option flexible	–	EHFS	EHFS	EHFS	EHFS	EHFS
Option flexible/supported	–	EHFSI	EHFSI	EHFSI	EHFSI	EHFSI
Impulse lightning voltage	kV	350	550	650	750	750
Normative document	IEC	60840 60815	60840 60815	60840 60815	60840 60815	62067 60815
Cu/Al conductor (min.)	mm ²	95	150	240	240	400
Cu/Al conductor (max.) ***	mm ²	1200	1200	1600	1400	1200
Rated current (max.) **	A	3150	3150	3150	3150	3150
Rated peak current **	kA	170	170	170	170	170
Rated short-time withstand current **	kA/s	50/3 63/1	50/3 63/1	50/3 63/1	50/3 63/1	50/3 63/1
Standard pollution class	–	≥ d/III heavy	≥ d/III heavy	≥ d/III heavy	≥ d/III heavy	≥ d/III heavy
Length with class d/III (approx.) [L]	mm	1100	1620	2640	2640	2640
Weight with class d/III (approx.) ****	kg	10	18	40	40	40

Highest voltage U_m	kV	72.5	123	145	170
Option self-supporting	–	EHFST	EHFST	EHFST	EHFST
Impulse lightning voltage	kV	350	550	650	750
Normative document	IEC	60840 60815	60840 60815	60840 60815	60840 60815
Cu/Al conductor (min.)	mm ²	95	150	240	240
Cu/Al conductor (max.)	mm ²	2500	2500	2500	1200
Rated current (max.) **	A	3150	3150	3150	3150
Rated peak current **	kA	170	170	170	170
Rated short-time withstand current **	kA/s	50/3 63/1	50/3 63/1	50/3 63/1	50/3 63/1
Standard pollution class	–	≥ d/III heavy	≥ d/III heavy	≥ d/III heavy	≥ d/III heavy
Length with class d/III (approx.) [L]	mm	1700	1700	1700	1700
Weight with class d/III (approx.) ****	kg	120	120	120	120
Base plate dimensions [a] *	mm	420	420	420	420
Hole distance [b] *	mm	345	345	345	345
Hole diameter [Ø c] *	mm	18	18	18	18
Bolt diameter [Ø d]	mm	30/50	30/50	30/50	30/50
Bolt length [l]	mm	100	100	100	100

Table 5 Data sheet for dry outdoor terminations

* Only for option self-supporting
 ** Depending on cable conductor cross-section
 *** Other cross sections on request
 **** Without cable

SEHDV 72.5 kV – 170 kV

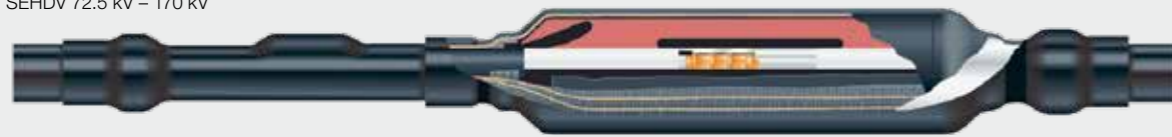

SEHDVCB 245 kV – 550 kV

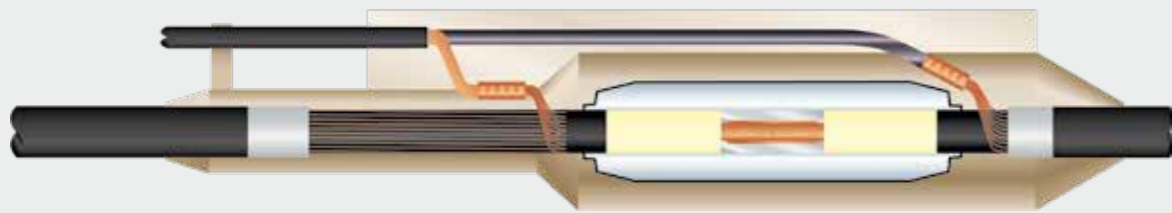

Cable joints SEHDV(CB)

72.5 kV – 550 kV

Properties

- The slim-line, one piece design of the silicone-rubber joint allows for easy assembly
- Integrated metallic water barrier
- Allows for connection of conductors with different cross-sections and materials
- Corrosion protection for standard-variant with one or more heatshrinkable tubing for voltage levels up to 170 kV; from 245 kV to 550 kV only for installations in air
- Meets the requirements of relevant test specifications (e.g. IEC 60840, IEC 60840 Annex G, IEC 62067, IEC 62067 Annex G)
- Optional up to 170 kV: corrosion protection with a cast-resin filling in PVC tubing or fibreglass protective housing
- Corrosion protection with a cast-resin filling in a fibreglass protective housing for all in-ground applications from 245 kV to 550 kV
- Corrosion protection variants with metal casing (for lead- and aluminium-sheathed cables) available

Highest voltage U_m	kV	72,5	123	145	170
Variant	–	SEHDV(CB)	SEHDV(CB)	SEHDV(CB)	SEHDV(CB)
Impulse lightning voltage	kV	350	550	650	750
Switching impulse voltage	kV	-	-	-	-
Impulse lightning voltage screen separation	kV	60	75	75	75
Impulse lightning voltage outer protection	kV	30	37,5	37,5	37,5
Direct voltage outer protection	kV	20	20	20	20
Normative document	IEC	60840	60840	60840	60840
Cu/Al conductor (min.)	mm ²	95	150	240	240
Cu/Al conductor (max.)	mm ²	2500	2500	2500	2500
Rated current (max.) *	A	2500	2500	2500	2500
Rated peak current *	kA	170	170	170	170
Rated short-time withstand current *	kA/s	50/3 63/1	50/3 63/1	50/3 63/1	50/3 63/1
Length insulation body (approx.)	mm	540	680	680	680
Weight of standard-variant (approx.) **	kg	15	30	30	30
Max. longitudinal force effect (in-air installation)	kN	20	20	20	20
Max. longitudinal force effect (in-ground installation)	kN	30	30	30	30

Table 6 Data sheet for joints, 72.5 – 550 kV

* Depending on cable conductor cross-section

** Without cable

Highest voltage U_m	kV	245	300	362	420	550
Variant	–	SEHDV(CB)	SEHDV(CB)	SEHDVCB	SEHDVCB	SEHDVCB
Impulse lightning voltage	kV	1050	1050	1175	1425	1550
Switching impulse voltage	kV	-	850	950	1050	1175
Impulse lightning voltage screen separation	kV	95	95	125	125	145
Impulse lightning voltage outer protection	kV	47,5	47,5	62,5	62,5	72,5
Direct voltage outer protection	kV	20	20	20	20	20
Normative document	IEC	62067	62067	62067	62067	62067
Cu/Al conductor (min.)	mm ²	400	400	500	630	800
Cu/Al conductor (max.)	mm ²	2500	2500	3200	3200	3200
Rated current (max.) *	A	2500	2500	2500	2500	2500
Rated peak current *	kA	170	170	170	170	170
Rated short-time withstand current *	kA/s	50/3 63/1	50/3 63/1	50/3 63/1	50/3 63/1	50/3 63/1
Length insulation body (approx.)	mm	740	740	900	900	900
Weight of standard-variant (approx.) **	kg	50	50	380	380	380
Max. longitudinal force effect (in-air installation)	kN	20	20	20	20	20
Max. longitudinal force effect (in-ground installation)	kN	30	30	30	30	30

Table 6 continued Data sheet for joints, 72.5 – 550 kV

* Depending on cable conductor cross-section

** Without cable

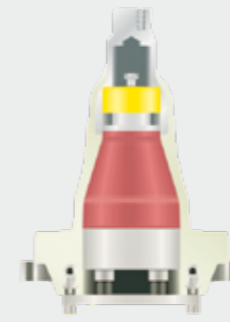

Fitting material for cable accessories

Dead-end flange for insulator compact terminations

- For testing insulators as well as switchgears with compact insulator without cable connection (switchgear test voltage)
- Can be used at reduced test voltages for insulators installed in transformer oil
- The Dilo valve is used to apply necessary SF₆ test pressures within the insulator
- Four different sizes for insulator types A/B, C/D/G, E, and F

Link boxes

Südkabel offers a wide variety of link boxes for cross-bonding or grounding one or both sides of the cable screens. The catalogue features boxes for rack, wall or pedestal mounting (protection degree IP66), as well as for horizontal or vertical installation in subterranean shafts or directly in the ground (protection degree IP68).

- Made of coated stainless steel
- Single-phase or three-phase variants available
- Up to six sheath voltage limiters (SVL) can be installed in boxes for screen cross-bonding and for single-end screen bonding
- Peak withstand and short-time withstand current-resistant design (usually 40 kA/ 1s, in custom variants up to 63 kA/1 s rated short-time withstand current)
- Arcing tested (usually 40 kA/ 0.1 s)

Fitting device for compact terminations

- For accurate, effortless mounting of the compact termination top connector

Radio-frequency earthing for GIS terminations

Switching activity in gas-insulated switchgears can lead to radio-frequency voltage transients at the insulator collar in terminations. To counteract this, Südkabel offers short, flexible connectors (usually with a SVL ≤ 1kV) that are mounted radially around the insulator collar.

EHSVSM GIS/transformer dead-ends

- EHSVSM dead-ends for voltage-stable, contact-protected termination of built-in insulators in SF₆ gas-insulated switchgears, or oil-filled transformers without cable connection
- The facility can be operated without pressure monitoring or risk to humans
- Very simple mounting without the need for specialised personnel
- When GIS/transformer dead-ends are removed, the corresponding compact termination can be inserted and the system re-energised
- Suitable for voltages up to max. 2.5 U₀

GIS/transformer connection adapters

In addition to conventional interfaces for compact terminations Südkabel can produce custom variants for almost all types of connector bolts and connector flanges in accordance with IEC 62271-209 and EN 50299.

Installation tools

Südkabel offers the entire range of specialised installation tools, such as stripping tools, compression tools, cutting tools, etc.

Compact termination insulator

- Adapter to make all available gas-insulated switchgears, bushings and transformers (SF₆ and climate-friendly substitute gases) compatible with compact terminations from Südkabel
- Installation in all current models, including retroactive installation to use dry compact terminations as a replacement for conventional oil-filled terminations

Cable cleaner RUK 500

- Soaked cleaning cloths for removing installation residues such as dust, oil or grease from cable sheathing and insulation

Plastic cable clamps

- Fibreglass-reinforced polyamide cable clamps for secure, short circuit-proof mounting of single- and multicore XLPE-insulated cables
- Flame retardant polyamide, dyed black for UV resistance
- Two-part clamps consisting of an upper and a lower section
- Obligatory rubber insert
- Consistent resistance values for temperature ranges encountered in the field
- Mechanical short-circuit stability up to 20 kN
- Can be used for light cables in any type of installation; with heavy cables, use only in horizontal sections

Sheath voltage limiter (SVL)

- For cable screen cross bonding and for single-end screen bonding
- Size of metal-oxide arrestors determined by maximum expected failure voltage (generally max. approx. 10 kV)

Test adapter

- For high-voltage testing of an XLPE-insulated cable system prior to mounting the EHSVSM or EHTVSM compact terminations in the GIS or transformer
- Component usually includes test cable for test voltage supply
- Supplied with appropriate insulator sockets in a metal jacket tube filled with pressurised SF₆ gas

Current plug

- For voltage free current supply into a switchgear or a transformer through the insulator of a compact sealing end EHSVSM or EHTVSM

Protective cover with earthing connection for compact terminations

Protective covers are recommended for EHSVSM and EHTVSM compact terminations.

- Protects terminations that are already installed on cables, but not yet connected, from mechanical damage
- Earthing point included

Silumin cable clamps

- Made of non-magnetic aluminium alloy
- For safe, short circuit-proof support of single-core XLPE-insulated cables
- Available in five basic sizes, each with different interior diameters
- Adaptable to outer cable end diameters by means of a rubber insert
- Fixing material included
- At least 2 clamps in the central termination axis recommended to ensure correct termination functionality. A third solid clamp recommended for heavier cables.

Voltage-proof dead-ends for compact terminations

- SF₆ gas-filled, voltage-proof dead-end for EHSVSM and EHTVSM compact terminations
- Can be used to test cables not yet connected to the switchgear or transformer; voltage supplied from the opposite end

Our offer

Cables

- XLPE-insulated cables from 10 kV to 500 kV
- Temporary site cables up to 220 kV

Accessories

for medium, high, and extra-high voltage

- Outdoor terminations
- Conventional and compact terminations for SF₆ gas-insulated switchgears and transformers
- Cable joints
- Compact terminations for outer and inner cone systems
- Cable links for medium voltage
- Accessories for electrostatic precipitator cables

Services

- Consulting for application-related questions
- Training for installation personnel
- Cable laying and supervision of laying
- Installation of accessories
- Commissioning
- After-sales services

Cable systems

- Turnkey XLPE cable systems up to 500 kV
- AC and DC

Südkabel – everything at one site

- Founded 1898 in Mannheim, Germany
- Manufacturing of cables and accessories
- Own department for research and development
- International project
- Sales partners worldwide

Certified

- Environmental management ISO 14001
- Quality management ISO 9001
- Energy management ISO 50001
- Health and safety management ISO 45001
- Project management ISO 21500
- Safety Culture Ladder Level 3

Südkabel GmbH

Rhenaniastr. 12-30 | 68199 Mannheim | Germany

Tel.: +49 621 8507 01 | Fax: +49 621 8507 294

E-Mail: info@suedkabel.com

www.suedkabel.com



Note:

We reserve the right to make technical changes or modify the contents of this document without prior notice. With regard to purchase orders, the agreed particulars shall prevail. Südkabel does not accept any responsibility whatsoever for potential errors or possible lack of information in this document. We reserve all rights in this document and in the subject matter and illustrations contained therein. Any reproduction – in whole or in parts – is forbidden without Südkabel's prior written consent.

Copyright © 2025 Südkabel. All rights reserved.